

LDM 210 - LDM 220

Hands Free Reader

User
Manual



Publication, translation and reproduction total or partial of this document is strictly forbidden without authorization



MGP Instruments recommends that any work to be done while the instrument is powered should be done by qualified and authorized personnel.

Table of updates

R e v	Date	Issued by	Reason for modification	Pages modified
A	OCTOBER 28, 2003	J. PEREZ/S. LOPEZ	Edit and Translation to English.	ALL
B	DECEMBER 16, 2003	J. PEREZ	Wrong configuration of the two jumpers SS2 and SS3.	§3-1-2, page 13
			Replacing of "ort" translation by "range" translation.	§6-1-1, page 29
				§4-5, page 25

Table of contents

1.	General	1
1.0	Purpose	1
1.1	Of this document	1
1.2	Nomenclature	1
1.3	Presentation of the LDM 210 – LDM 220	1
2.	Description - Functionality.....	3
2.1	Description of the LDM 210.....	3
2.1.1	LDM 210 dosimeter reader	3
2.1.2	Power supply.....	5
2.1.3	Identification label	6
2.2	Description of the LDM 220.....	6
2.2.1	LDM 220 dosimeter reader	7
2.2.2	Identification label in the face of the LDM 220	8
2.3	Operation	9
2.3.1	Normal Operating Mode.....	9
2.3.2	Test Mode.....	10
2.3.3	The Digital Input/Output TOR.....	10
3.	Installation and start-up	11
3.1	LDM 210 and LDM 220 Configuration.....	12
3.1.1	Location of jumpers:.....	12
3.1.2	Operating Modes (SS2 et SS3).....	13
3.1.3	OPERATIONNAL Mode	14
3.2	Installation of the USB driver for the LDM 220	15
3.2.1	For WINDOWS 2000.....	15
3.2.2	For WINDOWS XP	17
4.	Operation.....	21
4.1	Recommendation of use	22
4.1.1	LDM210 22	
4.1.2	LDM220 22	
4.2	Operating significance of the lights	23
4.3	Example of status indicators with DOSIMASS/ DOSIMED / DOSIFAST	23
4.4	Reader usage.....	24
4.4.1	DOSIMASS Software	24
4.4.2	DOSIMED or DOSIFAST Software	24
4.4.3	Other Software	24
4.5	Troubleshooting Guide.....	25
5.	Preventive Maintenance	27

6.	Corrective Maintenance	29
6.1	Operating TEST Modes.....	29
6.1.1	Operating Modes (SS2 et SS3).....	29
6.1.2	Test Mode	29
6.1.3	AGC amplifier test Mode	29
6.1.4	Autonomous test Mode	29
6.2	Start-up of Maintenance Modes	30
6.2.1	REMOTE DOWNLADING AND PROGRAMING Mode.....	30
6.2.2	TESTS Mode.....	31
6.2.3	Reader in "TESTS" mode.....	32
7.	Spare parts, options	35
7.1	Spare Parts for the LDM 210.....	35
7.2	Spare Parts for the LDM 220.....	35
7.3	Software	35
8.	Technical Characteristics	37
8.1	Mechanical Characteristics of the LDM 210.....	37
8.2	Mechanical Characteristics of the LDM 220.....	37
8.3	Electrical Characteristics of the LDM 210	37
8.4	Electrical Characteristics of the LDM 220	38
8.5	LDM 210 Serial Link.....	38
8.6	LDM 220 USB link.....	38
8.7	Environmental Conditions LDM 210 and LDM 220	38
8.8	Input/output digital DIO LDM 210 and LDM 220	39
8.9	Dosimeter link with LDM 210 and LDM 220	40
9.	Glossary	41

Table of figures

Figure 1 :	Presentation of the LDM 210 reader	2
Figure 2 :	Presentation of the LDM 220 reader	2
Figure 3 :	LDM 210 Assembly Description	3
Figure 4 :	Description of the LDM 210 enclosure and PCB.....	4
Figure 5 :	Description of the LDM 210 power pack	5
Figure 6 :	LDM 210 Identification and presentation labels	6
Figure 7 :	LDM 220 Assembly Description	6
Figure 8 :	LDM 220 enclosure and PCB Description.....	7
Figure 9 :	Identification and front face labels for the LDM 220	8
Figure 10 :	LDM 210 and LDM 220 Block Diagram.....	9
Figure 11 :	Location of jumpers for the configuration of the LDM 210.....	12
Figure 12 :	Location of jumpers for the configuration of the LDM 220.....	13
Figure 13 :	View of the reader LDM 210 – LDM 220	21
Figure 14 :	Recommendation of use - LDM210.....	22
Figure 15 :	Recommendation of use - LDM220.....	22
Figure 16 :	Reader LDM 210 – LDM 220	24

Blank Page

1. General

1.1 Purpose Of this document

This document provides all the information necessary for the use, configuration and maintenance of the hands free readers models LDM 210 and LDM 220.

1.2 Nomenclature

Symbols "■" and "□" :

These symbols are used for the descriptions and details:

The symbol "■" corresponds to the first level of detail.

The symbol "□" corresponds to the second level of detail.

For legibility purpose these symbols are aligned vertically.

1.3 Presentation of the LDM 210 – LDM 220

These hands free readers allow centralized dosimetry software (DOSIMASS, DOSIMED or DOSIFAST) to communicate with a DMC 2000 and SOR family dosimeter.

The dosimeter reader LDM 210 exists in two versions:

- with power supply.
- with power supply and optional battery.

The dosimeter reader LDM 220 is connected to the USB port.



Figure 1 : Presentation of the LDM 210 reader



Figure 2 : Presentation of the LDM 220 reader

2. Description - Functionality

2.1 Description of the LDM 210

The LDM 210 dosimeter reader is provided with:

- An RS232 cable,
- A power supply suitable for use in Europe or U.S.



Figure 3 : LDM 210 Assembly Description

2.1.1 LDM 210 dosimeter reader

The plastic enclosure contains:

- Three transparent lenses (2) for LED protection.
- A label (1) attached to the enclosure front panel.
- An identification label (4) indicating the model and serial number of the readers as well as the power supply polarity.
- The UC (3) reader board. It includes:
 - An antenna that allows communication with the dosimeter within a nominal range of 20 to 30 cm. The antenna is attached to the printed circuit board,
 - A power connector JACK (J8),
 - A female DB-9 connector (J6) for the RS232 serial connection,
 - A 14 pin male connector (J15) for the analog inputs and outputs,
 - A 14 pin male connector (J16) for the reader configuration mode,
 - Three bicolor diodes green and red for "Power", "Access" and "Status" (CR2, CR3 and CR4),
 - An enclosure with a battery compartment soldered to the PCB for the reader with the battery option.

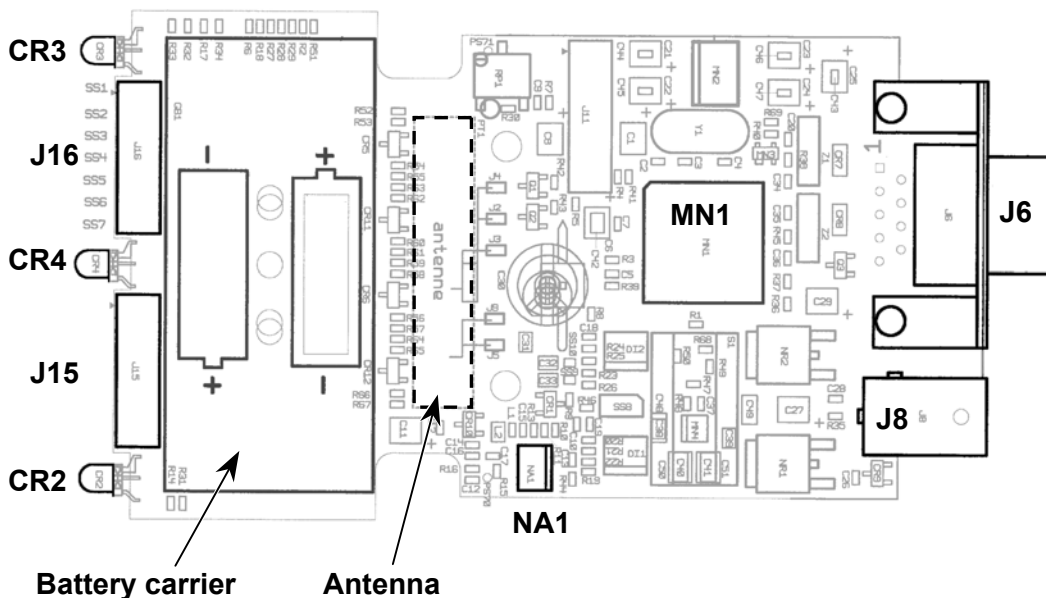
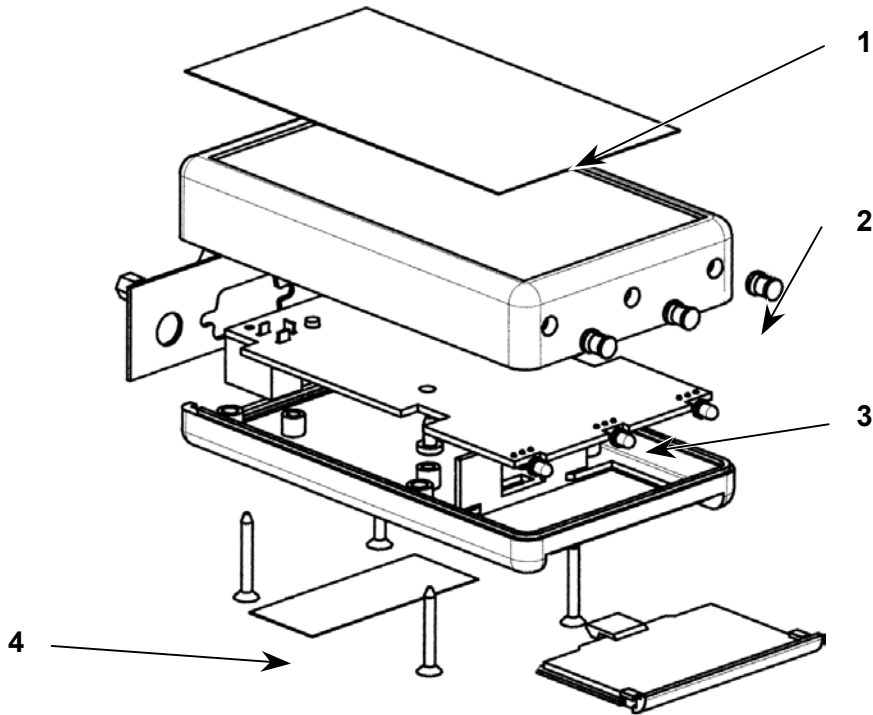

Figure 4 : Description of the LDM 210 enclosure and PCB

2.1.2 Power supply

The power supply provided is a 9 VDC output wall transformer for the LDM 210. It is connected to JACK J8.

Two interchangeable adapters allow the use of the power pack in places with the European or American standard. For other countries, consult MGP Instruments.



Figure 5 : Description of the LDM 210 power pack

2.1.3 Identification label

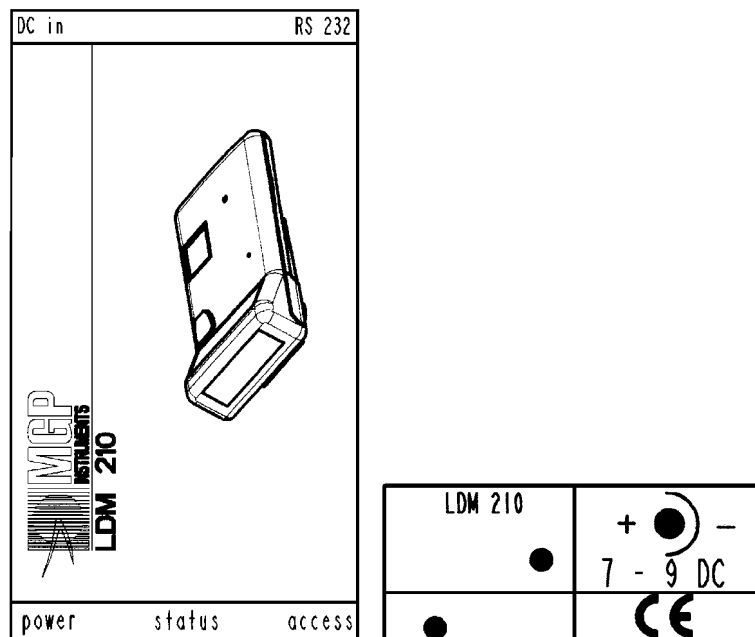

Figure 6 : LDM 210 Identification and presentation labels

2.2 Description of the LDM 220

The LDM 220 dosimeter reader assembly consists of:

- A plastic enclosure,
- An integrated USB cable,
- Three bicolor LED's.



Figure 7 : LDM 220 Assembly Description

2.2.1 LDM 220 dosimeter reader

The plastic enclosure contains:

- The reader PCB UC (1). It includes:
 - An Antenna (**ANT1**) located behind the UC (1) card that allows communication with the dosimeter within a nominal range of 20 to 30 cm. The antenna is attached to the printed circuit board,
 - A 5 pin male connector (**J1**) for the connection to the USB cable,
 - A 14 pin male connector (**J15**) for the analog inputs and outputs,
 - A 14 pin male connector (**J16**) for the reader configuration mode,
 - Three bicolor LED's green and red for "Power", "Access" and "Status" (**CR2, CR3 and CR4**),
- A label (2) glued to the enclosure front panel.
- An identification label indicating the model and serial number of the Reader.

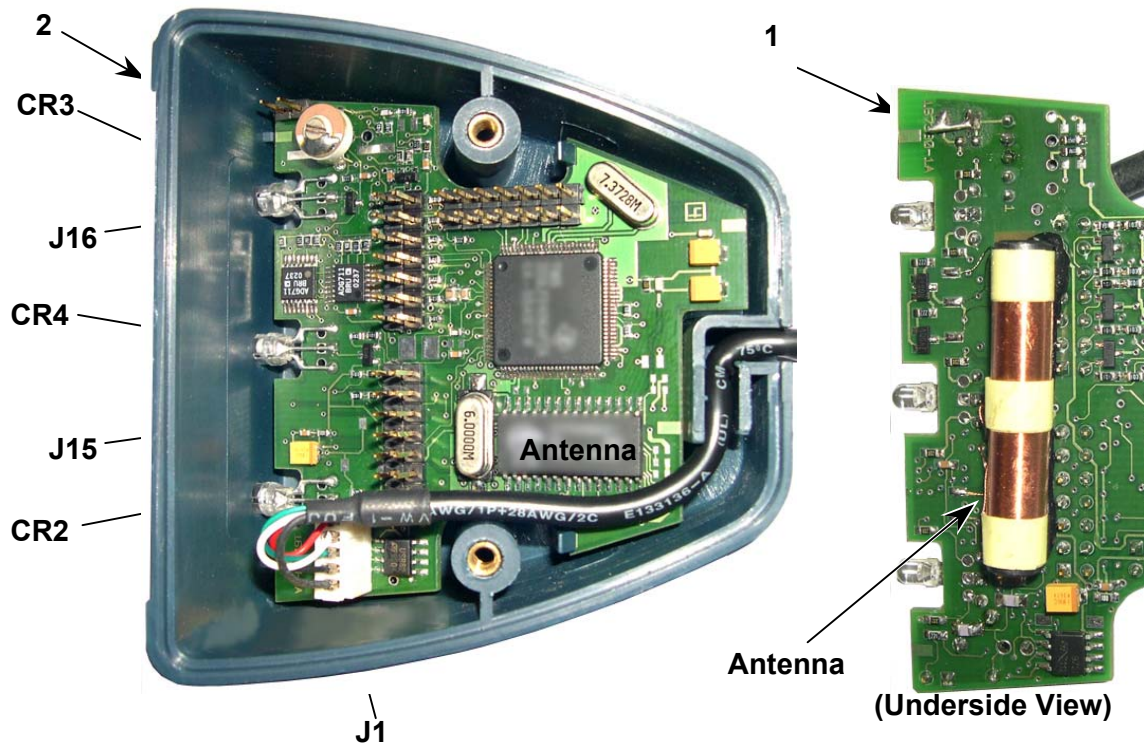

Figure 8 : LDM 220 enclosure and PCB Description

2.2.2 Identification label in the face of the LDM 220

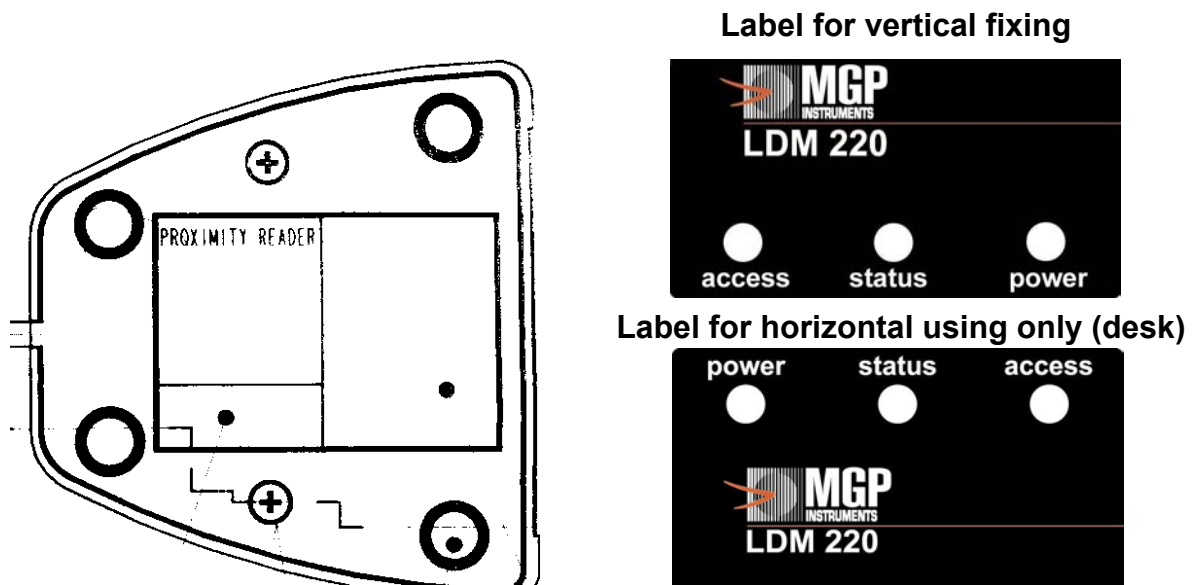

Figure 9 : Identification and front face labels for the LDM 220

2.3 Operation

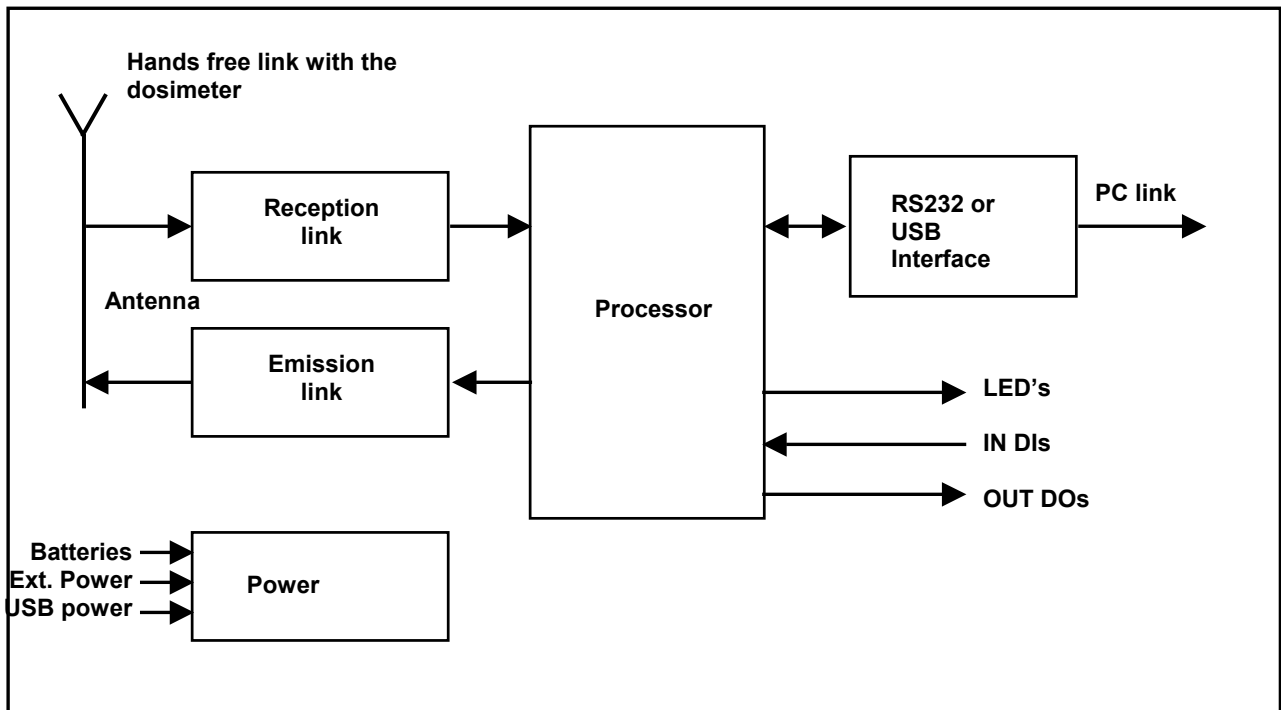

Figure 10 : LDM 210 and LDM 220 Block Diagram

The following operating modes are defined by the position of jumpers in the J16 connector (see § 3.1, page 12).

- Normal Operating Model.
- Test Mode.

2.3.1 Normal Operating Mode.

This is the normal operating mode of the reader. In this mode, the reader functions as a slave of the PC.

- It receives commands from the PC.
- It searches for a dosimeter.
- It executes commands – reading or writing dosimeter parameters or information.
- It transmits a report to the PC.

2.3.1.1 Retries

By default, the reader resends messages 10 times if the dosimeter fails to respond.

It is possible to disable the retries by relocating jumper SS4.

2.3.1.2 Reduced range

By default, the reader has a normal range of approximately 20 cm.

It is possible to reduce the range by relocating jumpers SS5 and SS8.

2.3.2 Test Mode.

It is a mode designed to verify proper functioning of the reader.

Refer to Corrective Maintenance in page 29.

2.3.3 The Digital Input/Output TOR

4 inputs and 4 outputs are managed by the reader by PC command.

These input/outputs are accessible on the HE10 male 2x7 pin 2.54 mm (0.1"0 spacing connector).

They are protected against electrostatic discharge by protection diodes.

Inactive status (no exterior cable) of the inputs is a high level 3.3 V (pull up).

Active status is low-level 0 V.

Inactive status (by default) of the outputs is low 0 V.

Active output status is high-level 3.3 V.

These input/outputs can be used for example in an access control case:

- Access LED authorized or refused.
- Locking of access.
- System busy or available.
- Authorization request of passage, etc.

3. Installation and start-up



Keep the reader away from sources of electromagnetic fields (video terminals, power supplies, PC, rotary machines, etc.)

Keep readers away from each other to prevent them from interfering with one another (in case this is not possible, adjust the range of the readers accordingly)

Keep readers at least 5 cm (2") from metallic surfaces.

The installation and start-up of the reader consists in sequence:

- Install the software on the PC.
- Connect power to the reader (LDM 210 only).
- Connect the reader to the PC.

Note :

The LDM 210 can be equipped with an optional 2 alkaline AAA1.5 V batteries for operation without an external power supply.

The LDM 220 is delivered for desk using (horizontally). It can be used in vertical fixing; a specific label is delivered for this use.

3.1 LDM 210 and LDM 220 Configuration

By default, the reader is delivered from MGP Instruments in "Operating Mode" with retries and with normal range.
No jumper is positioned.

3.1.1 Location of jumpers:

Jumper	DESIGNATION
SS1 *	Remote access 1
SS2 *	Operating Mode
SS3 *	Operating Mode
SS4	Retries
SS5 *	Reduced range
SS6 *	Remote access 2
SS7	RESET
SS8	Reduced range 2

* Read and effective after Reset (loss of power) or after locating jumper SS7.

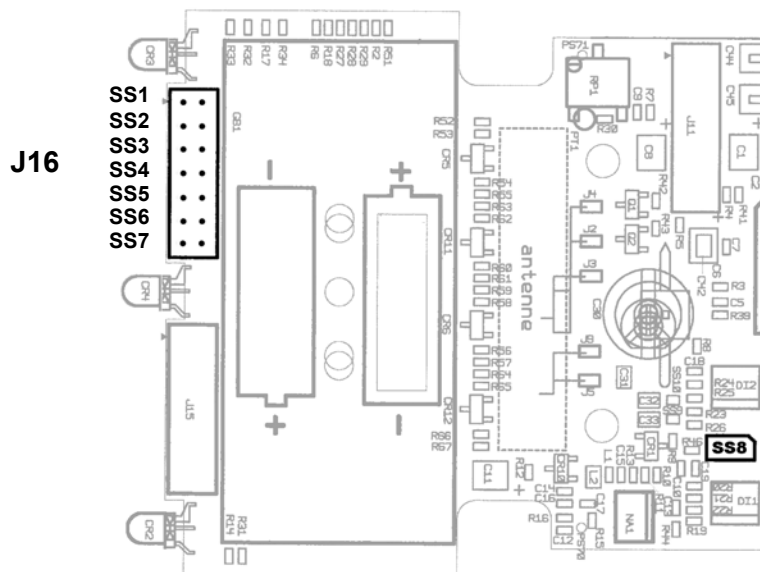

Figure 11 : Location of jumpers for the configuration of the LDM 210

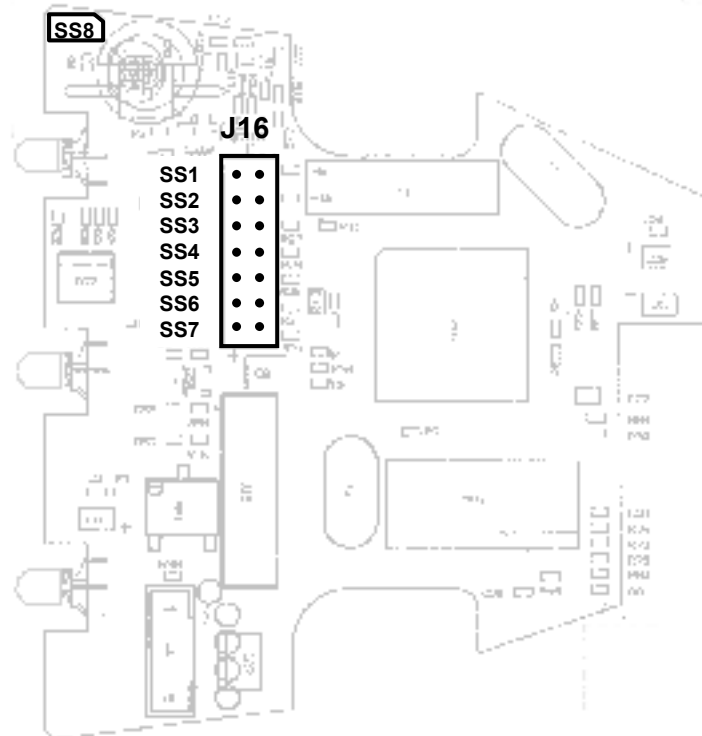

Figure 12 : Location of jumpers for the configuration of the LDM 220

3.1.2 Operating Modes (SS2 et SS3)

These two jumpers are used to configure the reader in the four possible operating modes:

SS2	SS3	Operating Mode
Removed	Removed	Normal Mode
Removed	Installed	AGC programmable amplifier test Mode
Installed	Removed	Various Tests Mode
Installed	Installed	Autonomous test Mode

3.1.3 OPERATIONNAL Mode

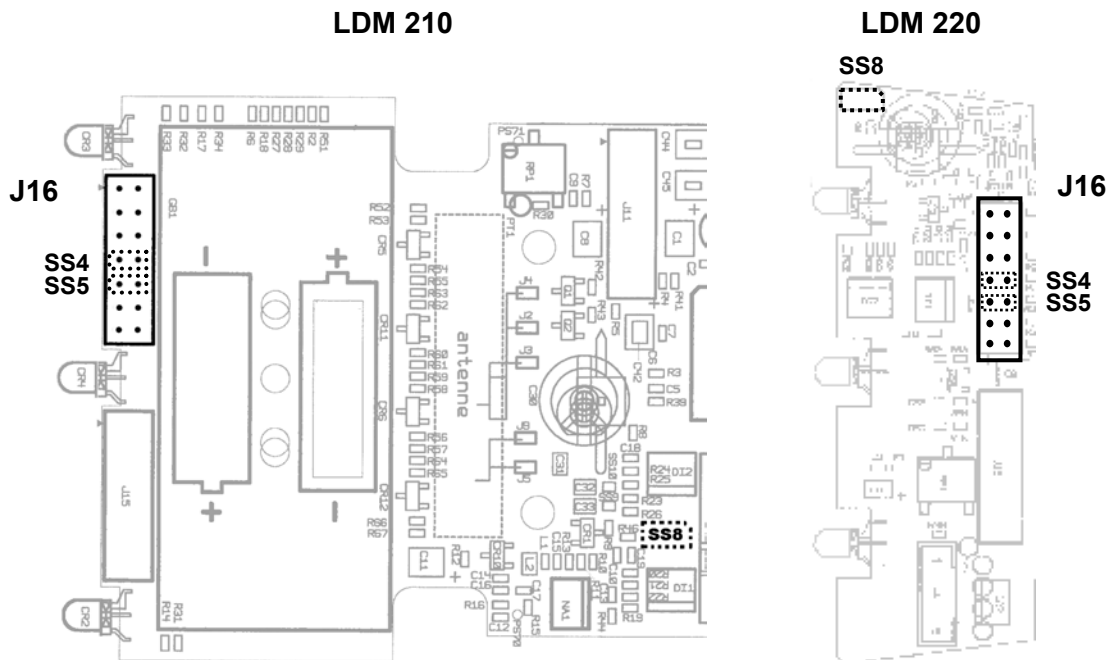

The operational mode is obtained when jumpers SS2 and SS3 are not installed and the remote programming mode is not selected.

In this mode the green power LED is lit after power is applied.

Then it is possible to:

- Authorize reader retries if SS4 is not installed,
- Forbid them if SS4 is installed.

Hands free range adjustment

The reader can be configured in:

- Normal range if SS5 and SS8 are not installed,
- Reduced range if SS5 and SS8 are installed.

3.2 Installation of the USB driver for the LDM 220

Certain software applications like Dosimass, Dosimed and Dosifast automatically install the specific USB driver required by the LDM 220 reader.

3.2.1 For WINDOWS 2000

To verify proper installation of the driver on WINDOWS 2000:

- Connect the LDM 220 reader to the USB port after installing the driver.
- From WINDOWS, select the My Computer icon and right click.
- Select "Properties".
- Select Hardware then "Device Manager".

- Open the list of Ports (COM and LPT) and verify the presence of the "COM device" port:
"Cypress USB-HID -> COM Device (COM)"

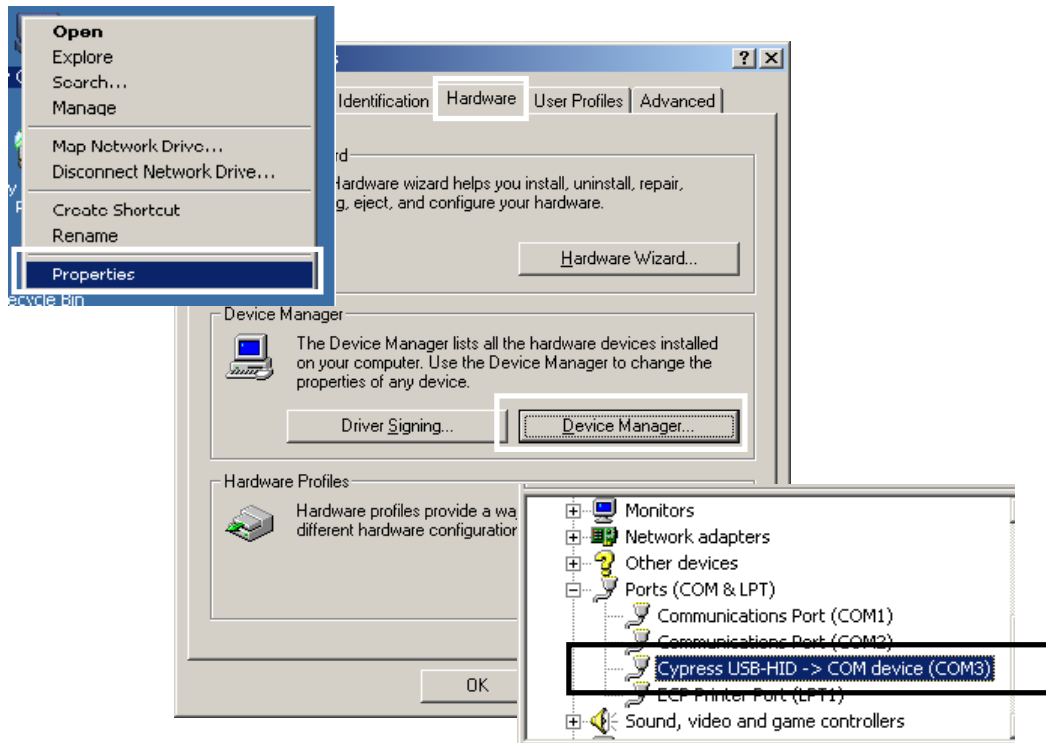

Note :

*Disconnect the LDM 220, the Port COM Device disappears.
Reconnect the LDM 220, the Port COM Device reappears.*

If the installation of the USB driver was not successful:

- Uninstall the old driver.
- Reinstall the driver starting from the file "HidComInst.exe" found in the installation CD-ROM.

3.2.2 For WINDOWS XP

3.2.2.1 Verify the installation of the USB driver

To verify proper installation of the driver on WINDOWS XP:

- Connect the LDM 220 reader to the USB port after installing the driver.
- From WINDOWS, select the My Computer icon and right click.
- Select "Properties",
- Select Hardware then "Device Manager".
- Open the list of Ports (COM and LPT) and verify the presence of the "COM device" port:
"Cypress USB-HID -> COM Device (COM) ":

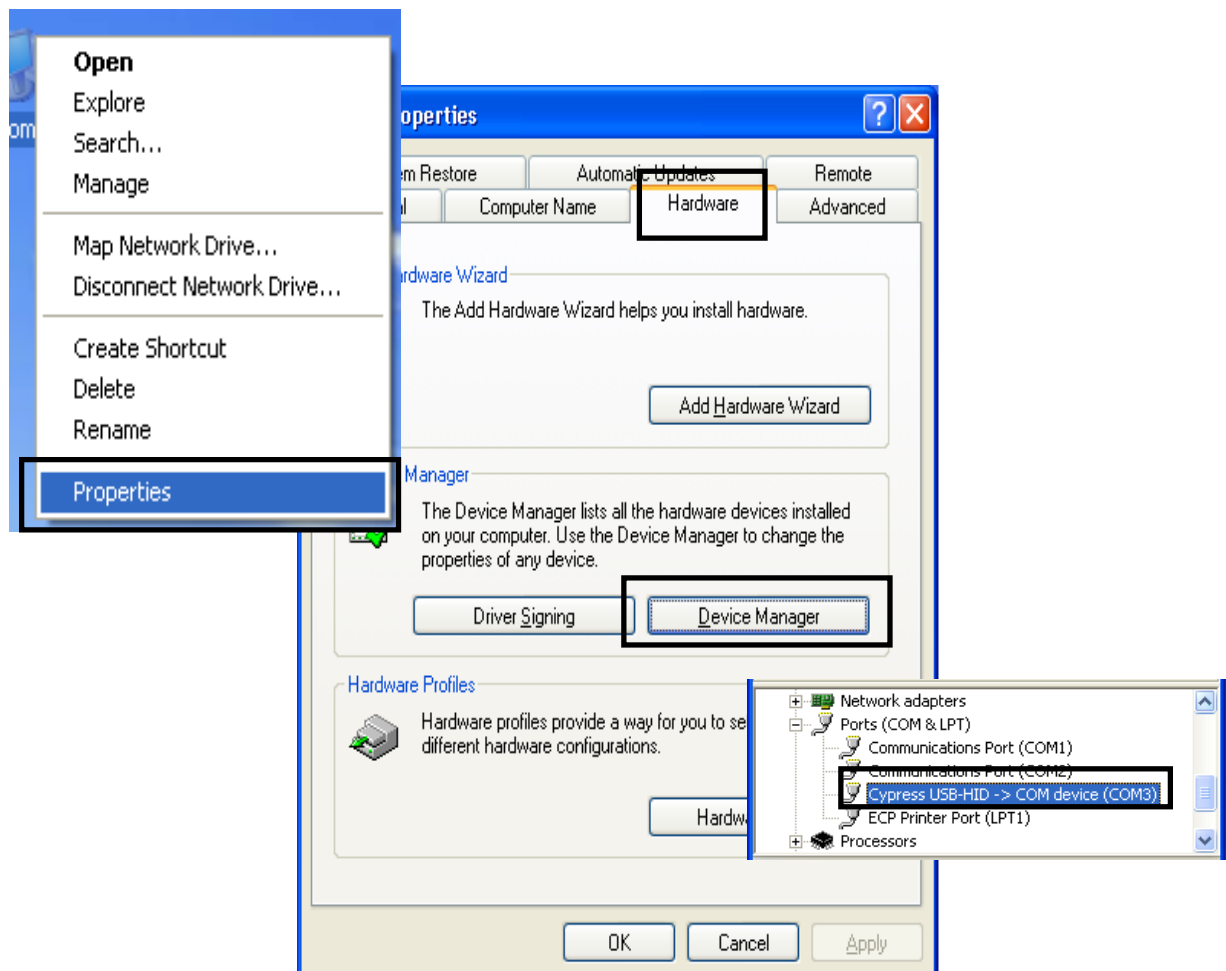

Note :

Disconnect the LDM 220 and the Port COM Device disappears.
Reconnect the LDM 220 and the Port COM Device reappears.

If the USB driver installation is not successful:

- Reinstall the driver starting from the file "HidComInst.exe" found in the installation CD-ROM. See following paragraph.

3.2.2.2 In case of installation failure of the USB driver

The USB driver USB for the LDM 220 has not been numerically assigned by WINDOWS XP.

In certain cases, after the first connection to the LDM 220, WINDOWS XP installs automatically the driver "user interface hardware (HID)". This peripheral does not manage the LDM 220.

When the "user interface hardware (HID)" is installed, manually install the LDM 220 driver:

- From WINDOWS, select the My Computer icon and right click.
- Select "Properties",
- Select Hardware then "Device Manager".

Open the list of Ports (COM and LPT) and verify the presence of the "COM device" port.
Right click on the USB interface.

- Select "Update..."

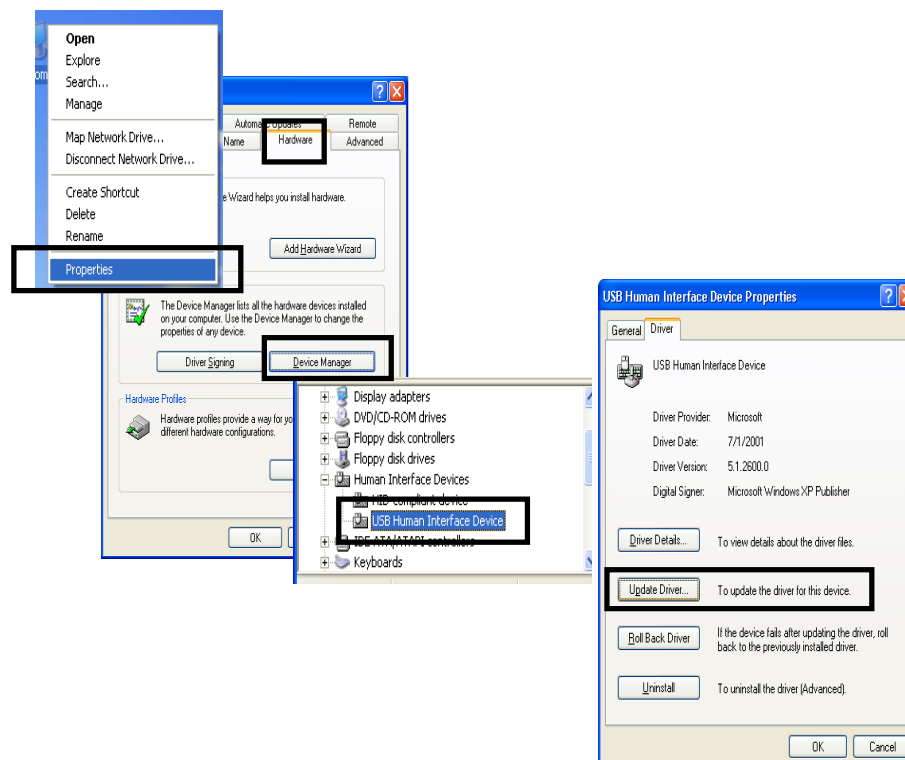

- Choose "Install from a specified location" and click on "Continue".
- Choose "Find the best option at this location", choose "Include this location in the search", click on "Continue" and select the directory containing the "Ccport.sys" driver. Click on "OK".

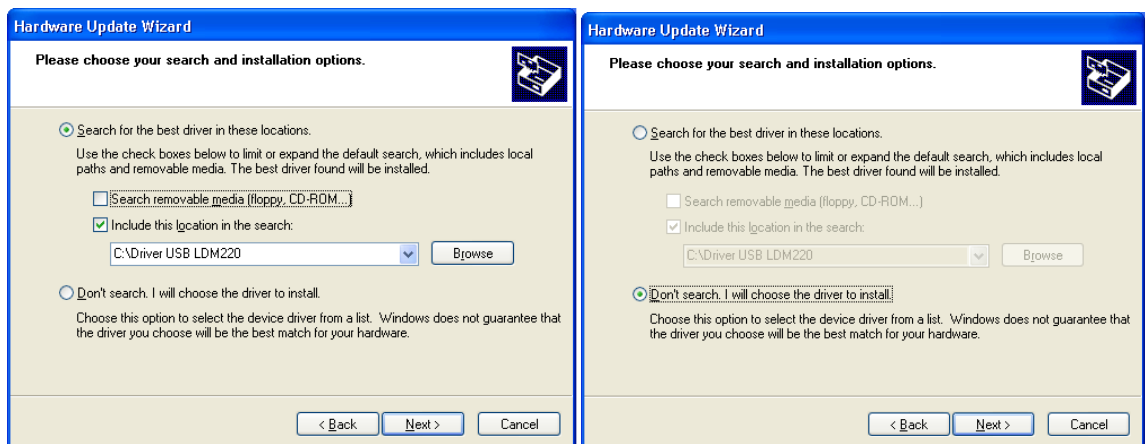

- Choose "Do not search. I will choose the driver to be installed "Continue".

- Select "Cypress USB-HID -> COM device" then click "Continue".

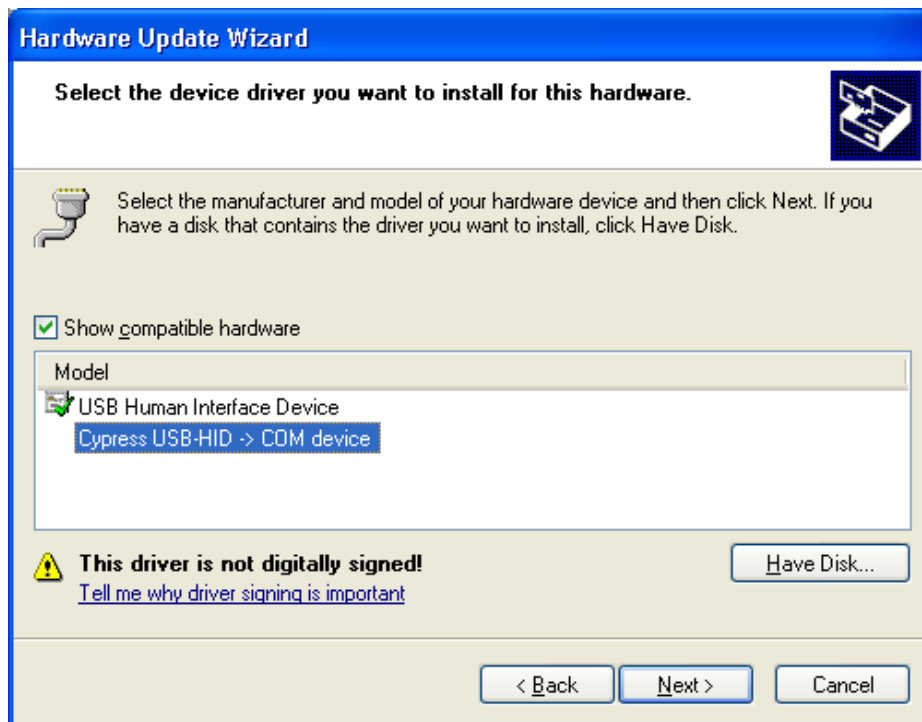

- On the device screen with WINDOWS XP compatibility, click "Continue".
- Click on "End".

4. Operation



Keep the reader away from sources of electromagnetic fields (video terminals, power supplies, PC, rotary machines, etc.)

Keep readers away from each other to prevent them from interfering with one another (in case this is not possible, adjust the range of the readers accordingly)

Keep readers at least 5 cm (2") from metallic surfaces.

The reader has no stand-alone function; it must be used connected to a PC using software provided by MGP Instruments.

Three bicolor LED's inform users about the status of exchange sequences with the dosimeter.

1 – Verify Go/Stop and Hands Free Operation (POWER)

2 – Status Management (READY/BUSY)

3 - Indication of passage (ACCESS/NO ACCESS)



Figure 13 : View of the reader LDM 210 – LDM 220

4.1 Recommendation of use

4.1.1 LDM210

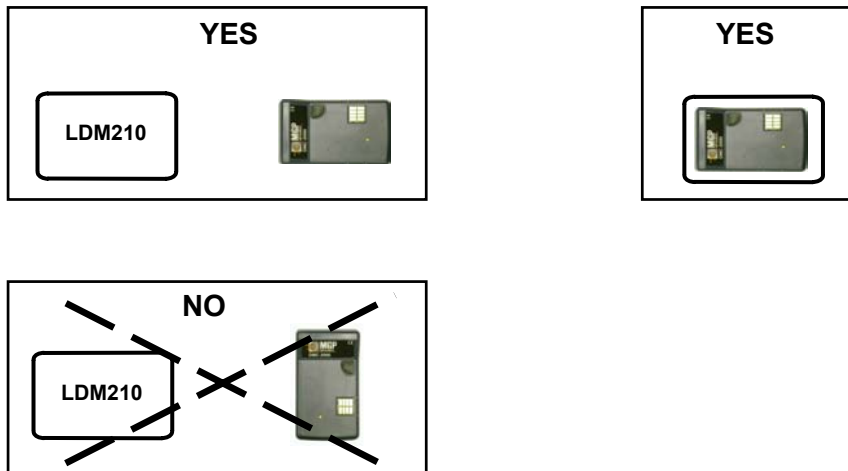

Figure 14 : Recommendation of use - LDM210

4.1.2 LDM220

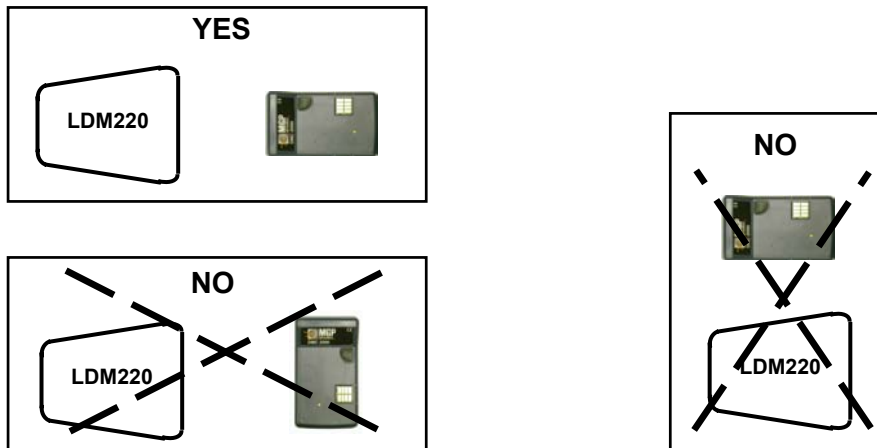

Figure 15 : Recommendation of use - LDM220

4.2 Operating significance of the lights

DESIGNATION	VIEW	STATUS
POWER	OFF Lit Green Lit Red	Reader power is OFF or sending a message to the dosimeter. Power OK flashes briefly while receiving a message from the dosimeter
STATUS	Depends on the logic of the software	
ACCESS		

4.3 Example of status indicators with DOSIMASS/ DOSIMED / DOSIFAST

POWER	STATUS	ACCESS	DESIGNATION
Blinking	Red	Red	Searching for a dosimeter
ON	Green	Red	Wait (between two searches)
Blinking	Red	Red	Dosimeter found, operation in progress
ON	Red	Green	Access authorized, operation complete

4.4 Reader usage

The reader can be associated with a variety of software applications each with its own system architecture.

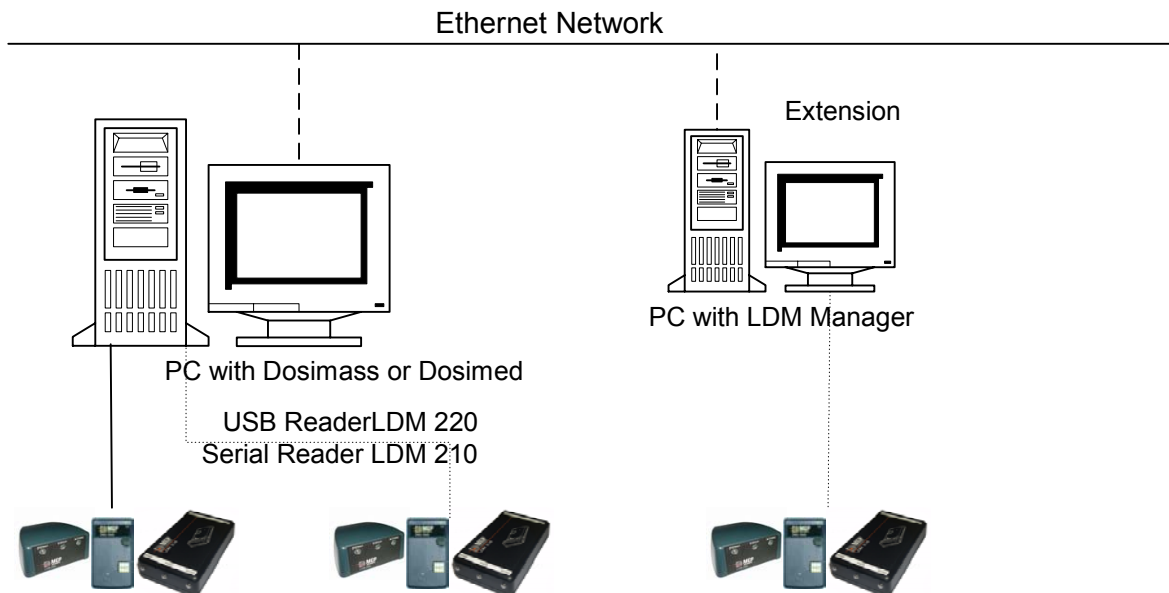

Figure 16 : Reader LDM 210 – LDM 220

4.4.1 DOSIMASS Software

DOSIMASS is a user utility software. It provides access to:

- All operational and configuration parameters stored in the dosimeter memory for both read and write functions.
- Reading histograms.

4.4.2 DOSIMED or DOSIFAST Software

DOSIMED and DOSIFAST are automatic management Software used for individual dosimetry. They have been specifically adapted for small installations.

4.4.3 Other Software

MGP Instruments has developed utilities to help software developers for specific clients. Contact MGP Instruments for further details.

4.5 Troubleshooting Guide

Symptoms	Analysis	Remedy
The green POWER LED does not lit after applying power.	Verify proper configuration of the jumpers. Continue use.	See § 3.1, page 12
	On the LDM 210, verify the power supply polarity on the connector JACK. On the LDM 210, check the power supply voltage (7-9 VDC)	 <p>Correct the polarity. Start the "VARIOUS TESTS" mode. If the fault persists, return the reader to MGP Instruments.</p>
	For a battery operated unit: - Check the status of the 2 1.5 V batteries.	Replace batteries with new ones with the same characteristics, see §8.3, page 37.
No communication with the PC	Verify that the reader is powered. Verify good connection with the RS232 or USB cable.	Start the "VARIOUS TESTS" mode.. See §6.2.2.1, page 31.
	Verify the proper configuration of the PC port.	Configure the port. If the fault persists, return the reader to MGP Instruments.
No data exchange with the dosimeter.	Eliminate all sources of electromagnetic emissions.	
	Verify that the reader is powered.	
	Verify communication with the PC	Start the self diagnostic and configure the reader in "Autonomous Mode", see §6.2.2.3, page 31 and execute procedure §6.2.3 page 32 If the fault persists, return the reader to MGP Instruments.
Defective range		Start the self diagnostic and configure the reader in "Autonomous Mode", see §6.2.2.3, page 31 and execute procedure §6.2.3 page 32. Verify the position of port jumpers; see § 2.3.1.2, page 10. If the fault persists, return the reader to MGP Instruments.
One of the LED's does not light	Configure the reader in "VARIOUS TESTS" mode ", see §6.2.2.1, page 31. Verify that the LED's are lit.	If the fault persists, return the reader to MGP Instruments..
Digital Input/output Problem	Configure the reader in "VARIOUS TESTS" mode ", see §6.2.2.1, page 31. Verify that the status of the DIO output corresponds to the inverse of the status of the input. DI1=0 -> DO1=1	If the fault persists, return the reader to MGP Instruments..

Blank Page

5. Preventive Maintenance

Not applicable.

Blank Page

6. Corrective Maintenance

6.1 Operating TEST Modes

6.1.1 Operating Modes (SS2 et SS3)

These two jumpers are used to configure the reader in the four possible operating modes:

SS2	SS3	Operating Mode
Removed	Removed	Normal Mode
Removed	Installed	AGC programmable amplifier test Mode
Installed	Removed	Various Tests Mode
Installed	Installed	Autonomous test Mode

6.1.2 Test Mode

It performs the following functions:

1. Energize the three bicolor LED's
2. Read the digital inputs DI1 to DI4, and set the inverse on outputs DO1 to DO4
3. Send the software version and revision as the first message sent to the PC
4. Test the hands free reception
5. Measure the battery voltage and transmit the voltage value to the PC for the LDM 210 reader RS232 version

6.1.3 AGC amplifier test Mode

It is a mode designed to verify the proper functioning of the programmable gain amplifier used by the automatic gain control system.

6.1.4 Autonomous test Mode

In this mode the reader continuously polls any dosimeter within range and send the data to the PC

6.2 Start-up of Maintenance Modes

6.2.1 REMOTE DOWNLADING AND PROGRAMING Mode

In this mode it is possible to download a new version of the software to the reader over the RS-232 link for the LDM-210 model or via the USB port for the LDM-220 model. This new version is stored in the flash memory of the reader DSP chip.

It is necessary to use a remote access software specific to the reader (contact MGP Instruments for details).

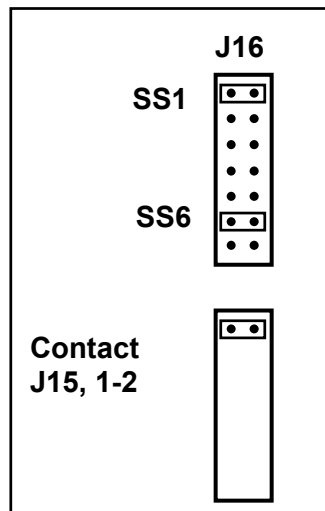

To enter this remote programming mode the jumpers should be positioned:

- Jumper SS1 (J16),
- Jumper SS6 (J16),
- One jumper over the contacts 1 and 2 of J15.

Use to download software to a remote PC.



To exit this programming mode you should install :

- jumper SS1,
- jumper SS6,
- jumper over contacts 1 and 2 of J15.

6.2.2 TESTS Mode

The operating mode of the reader is chosen at start-up.

The test modes are usable if the reader is not in the remote downloading mode.

Note :

The mode can be used with the "HyperTerminal" communication tool from Windows.

6.2.2.1 « Various Tests »

The «various tests» mode is obtained when jumper SS2 is installed and SS3 is not installed.

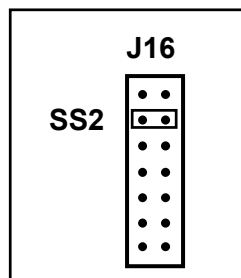

6.2.2.2 Test « AGC programmable amplifier »

The « AGC programmable amplifier » test mode is obtained when jumper SS2 is not installed and SS3 is installed.

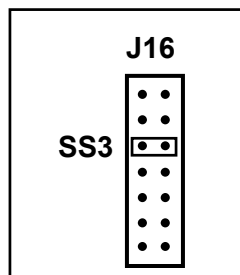

6.2.2.3 « autonomous » Test

The « autonomous » test mode is obtained when jumper SS2 and SS3 are installed.

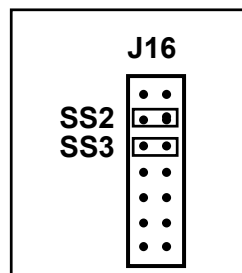

6.2.3 Reader in "TESTS" mode

This mode can be used with any communication program like Windows "HyperTerminal"

- Select "HyperTerminal" in the Windows accessories.

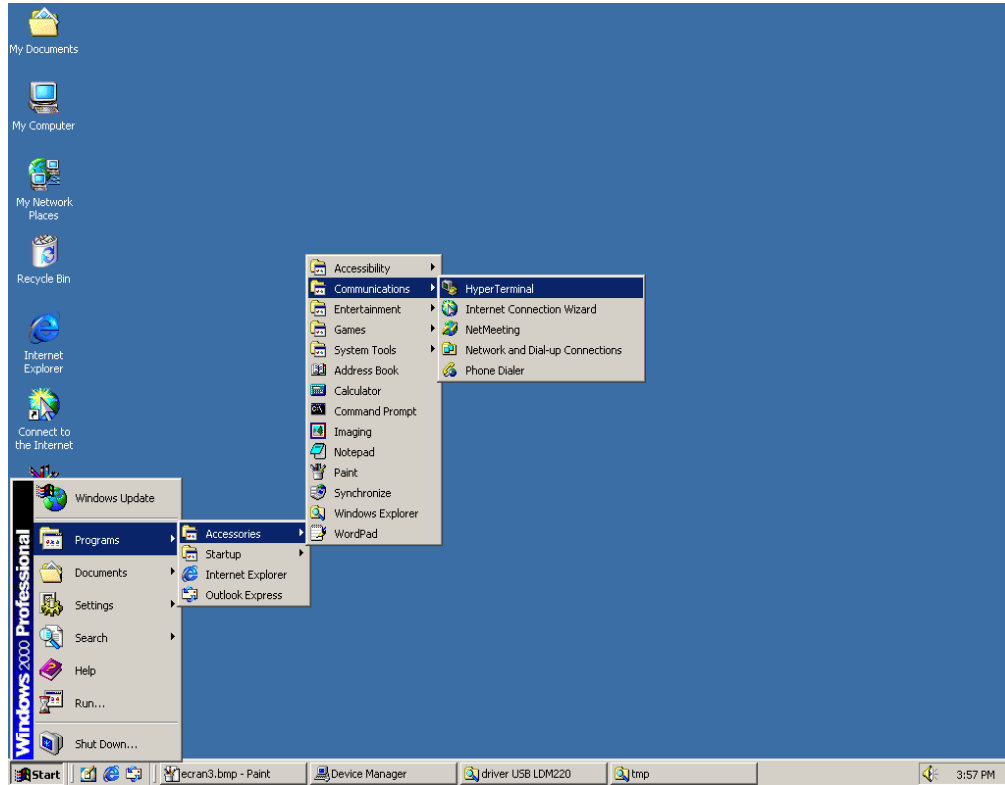

- The following screen will appear, enter a name and choose an icon. Validate by pressing OK.

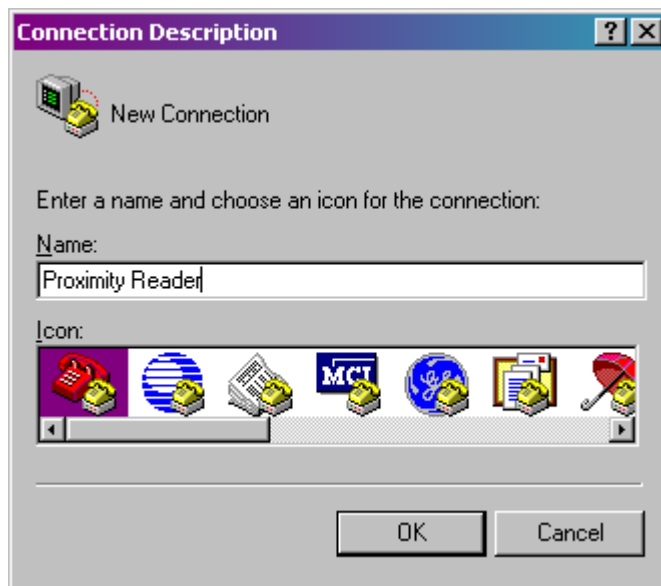

- In the following screen fill the required fields with your data
- Select a port to connect (COM1 for example)

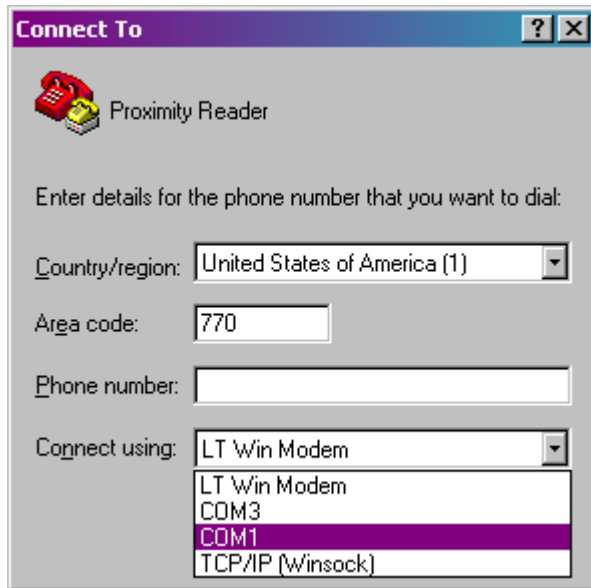

- Configure the selected port (COM1 for example) and in the field Flux Control, Select *None*. Validate by pressing OK

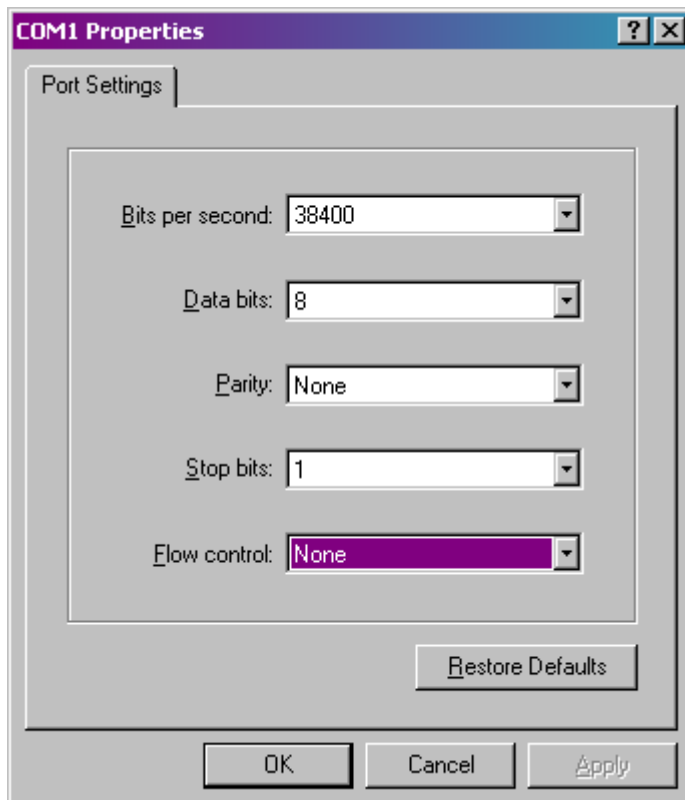

- The connection is established. Example of communication with a dosimeter:

```
Proximity Reader - HyperTerminal
Fichier Edition Affichage Appel Transfert ?
010F0037
010F0037
010F0037
010F0037
010F0037
010F0037
010F00240729009999-E0
010F0037
010F0037
Log:0927-1.6
010F0037
010F00240729009999-E0
010F00240729009999-E0
010F00240729009999-E0
010F0037
010F0037
010F00250248009999-DD
010F00250248009999-DD
010F00250248009999-DD
010F00250248009999-DD
010F0037
010F0037
010F0037
00:01:49 connecté  Détection auto  38400 8-N-1  DÉFIL  Maj  Num  Capturer  Écho
```

7. Spare parts, options

7.1 Spare Parts for the LDM 210

Description	MGP Instruments Part number
Reader Assembly (Europe and U.S. power supply + RS232 cable)	127275
Reader Assembly (Europe power supply. + RS232 cable)	128982
Reader Assembly (U.S. power supply. + RS232 cable)	128983
READER	126806
Europe and U.S. power pack 100-240 V, 9 VDC	71001071 or 71001383
Europe power pack 100-240 V, 9 VDC	71001367
U.S. power pack 100-240 V, 9 VDC	71001368
Reader Assembly with batteries holder	127274
Reader with batteries holder	126773
RS232 cable	70032131BA

7.2 Spare Parts for the LDM 220

Description	MGP Instruments Part Number
USB Reader assembly + USB cable	127868
USB Cable	127684

7.3 Software

Software application	MGP Instruments P/N
Software DOSIMASS	
Software DOSIMED	
Software DOSIFAST	
Software Development tools	Contact MGP Instruments

Blank page

8. Technical Characteristics

8.1 Mechanical Characteristics of the LDM 210

- Length: 110 mm
- Width 65 mm
- Depth 28 mm
- Weight: 110 grams
- PC to reader cable length: 1.80 m

8.2 Mechanical Characteristics of the LDM 220

- Length: 70 mm
- Width 80 mm
- Depth 32 mm
- Masse 120 grams
- PC to reader cable length: 2.00 m

8.3 Electrical Characteristics of the LDM 210

- Universal power supply
 - Input: 90 to 265 V AC - 47 to 63 Hz
 - Output 9 V DC
 - Delivered with US or European adapters
- Consumption: 100 mA typical over the 9 V DC
- Option:
 - Battery power, 2 batteries AAA 1.5 V
 - Battery life 10 h typical
- CE marking

8.4 Electrical Characteristics of the LDM 220

- Powered by the USB port: 4.15 V to 5.25 V.
- Conforms to CE requirements

8.5 LDM 210 Serial Link

- J6 female DB9 .

Pin number J6	Designation
1	Not used
2	TX
3	RX
4	Connected to pin 6 by the PCB
5	GND
6	Connected to pin 4 by the PCB
7	Connected to pin 8 by the PCB
8	Connected to pin 7 by the PCB
9	Not used

8.6 LDM 220 USB link

- J1 male 5 pins connector

Pin number J1	Designation
1	Vbus (Red)
2	D- (white)
3	D+ (green)
4	GND (black)
Shell	Shield

8.7 Environmental Conditions LDM 210 and LDM 220

- Operating Temperature: 0 to +50°C
- Storage Temperature -10°C to +60°C
- Relative humidity:
(without condensation) 90%

8.8 Input/output digital DIO LDM 210 and LDM 220

- Connector J15 male HE10 2x7 pins.
- 4 inputs and 4 outputs are available on the J15 connector.

Pin number J15	Designation
1	GND
2	INPUT Digital Input 3
3	INPUT Digital Input 1
4	OUTPUT Digital Output 1
5	INPUT Digital Input 2
6	OUTPUT Digital Output 2
7	INPUT Digital Input 4
8	OUTPUT Digital Output 3
9	3.3 V
10	OUTPUT Digital Output 4
11	5 V
12	GND
13	5 V
14	GND

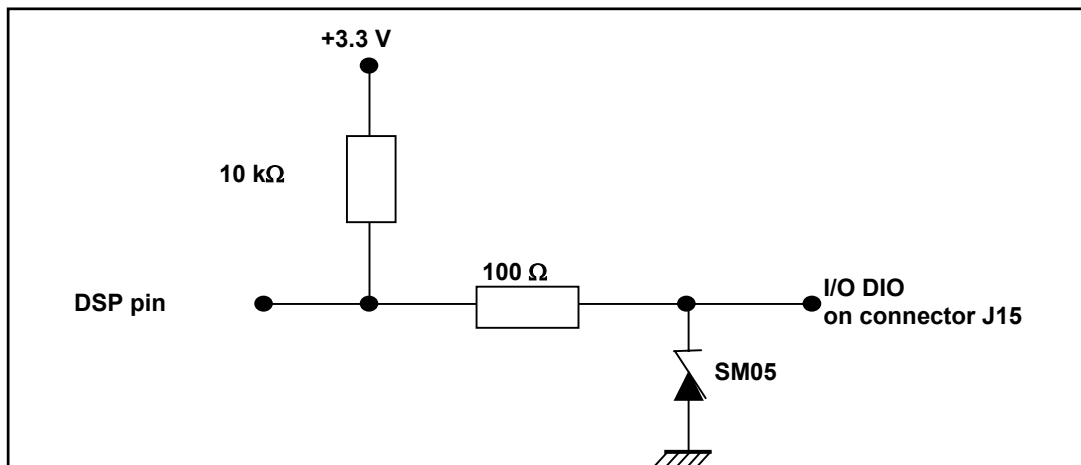

- DSP INPUT levels:
 - VIH 2 V min.
 - VIL 0.8 V max.
- DSP Outputs levels:
 - VOH 2.4 V min.
 - VOL 0.4 V max.

- Output current
- IOH 4 mA max. Except DO N°1 8 mA max.
- IOL -4 mA max. Except DO N°1 8 mA max.

8.9 Dosimeter link with LDM 210 and LDM 220

- Communication with dosimeters in hands free mode:
 - Nominal port (SS5 and SS8 Removed): between 20 and 30 cm
 - Reduced range port (SS5 and SS8 Installed): between 5 and 20 cm

9. Glossary

AGC	A utomatic G ain C ontrol
DIO	D igital I nput O utput
DSP	D igital S ignal P rocessor
IOH	I ntensity O utput H igh
IOL	I ntensity O utput L ow
LED	L ight E mitting D iode
PC	P ersonal C omputer
ROM	R ead O nly M emory
RS 232	Standard serial protocol
Ddi	D igital I nput
DO	D igital O utput
VIH	V oltage I nput H igh
VIL	V oltage I nput L ow
VOH	V oltage O utput H igh
VOL	V oltage O utput L ow

Blank page

RETURN REMARKS

In order to improve updating of this manual, send us your comments and corrections by electronic mail to the following address:

documentation@mgpi.com.fr

Your "Return Remarks" will help us to satisfy you.
Thank you

References to be recalled with the "Return Remarks":

- Title, reference and index of manual.
- Chapter, paragraph and page concerned.

MGP Instruments
BP1
F-13113 Lamanon
Tél. : 33 +(0)4 90 59 59 59
Fax : 33 +(0)4 90 59 55 18

www.mgpi.com

128569B

MGP Instruments Inc.
5000 Highlands Parkway,
Suite 150
Smyrna, Georgia 30082
Tel : (770) 432 2744
Fax : (770) 432 9179

En raison de l'évolution des normes et du matériel, les caractéristiques données ne nous engagent qu'après confirmation par nos services.

Réalisation MGP Instruments – 05/2003
Format 112175C